

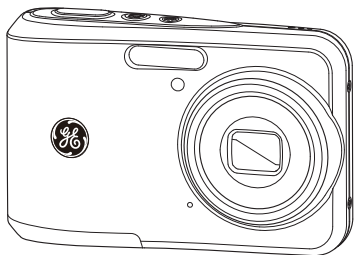

imagination at work

GE Digital Camera

Smart Series : C1640W



User Manual

Getting Started

Basic Operation

Camera Function Controls

Playback

Using the Menus

Camera Connectivity

Appendix

WARNING

Do not expose the camera battery pack or other accessories to rain or humidity to avoid a potential fire hazard or possible electric shock.

For customers in the U.S.A.

Tested To Comply With FCC Standards FOR HOME OR OFFICE USE

FCC Statement

This device complies with part 15 of the FCC Rules. Operation is subject to the following two conditions:

(1) This device may not cause harmful interference, and (2) this device must accept any interference received, including interference that may cause undesirable operation.

For customers in Europe



"CE" mark indicates that this product complies with the European requirements for safety, health, environment and customer protection. "CE" marked cameras are intended for sales in Europe.



This symbol [crossed-out wheeled bin WEEE Annex IV] indicates separate collection of electrical and electronic waste in the European countries. Please do not throw the equipment into the waste. Please recycle and dispose of properly.

Declaration of Conformity

Model Name: C1640W

Trade Name: GE

Responsible Party: General Imaging Co.

Address: 1411 W. 190th Street, Suite 550, Gardena,
CA 90248, U.S.A.

Customer Service Telephone Number:
+1-800-730-6597

(Outside U.S. & Canada: +1-310-755-6857)

SAFETY PRECAUTIONS

Camera Notes:

! Do not store or use the camera in the following environments:

- In the rain, in humidity or dusty environments.
- In a place where the camera can be exposed directly to sunlight or subject to high temperatures, e.g. inside a closed car in summer.
- In a place where the camera is subject to a high magnetic fields, e.g. near motors, transformers or magnets.

! Do not place the camera on a wet surface or places where dripping water or sand may come in contact with the camera.

! If the camera will not be used for a long period of time, removing the battery and the memory card from the camera and storing them in a dry environment.

! If you carry the camera suddenly from a cold location to a warm place, moisture may condense inside the camera. It is suggested that you wait for a while before turning this camera on.

! Warranty does not cover any type of data loss or corruption.

Battery Notes:

! Incorrect use of the battery may cause it to leak, become hot, ignite or burst. Always observe the following precautions:

- Do not expose the battery to water and take particular care to keep the terminals dry.
- Do not heat the battery or throw it into a fire.
- Do not attempt to deform, disassemble or modify the battery.

! Keep the battery out of reach of babies and small children.

! In cold locations, battery performance deteriorates and battery life is significantly shortened.

Memory Card Notes:

! When using a new memory card, be sure to format the card with your digital camera before using it.

! Do not change folder or file name of the memory card in the computer. An edited file cannot be displayed on the LCD screen of the camera. To edit image data, please copy the image data to the computer's hard disk drive first.

! The photos taken by this camera are stored in the auto-generated folder in the SD card. Please do not store photos that are not taken by this model of camera, as this may make it impossible to recognize pictures when the camera is in playback mode.

BEFORE YOU START

Preface

Thank you for purchasing this GE digital camera. Please read this manual carefully and keep it in a safe place for future reference.

Copyright

© Copyright 2013 General Imaging Company. All rights reserved.

No part of this publication may be reproduced, transmitted, transcribed, stored in a retrieval system, or translated into any language or computer language, in any form, by any means, without the prior written permission of General Imaging Company.

Trademarks

All trademarks mentioned in this manual are used for identification purposes only and are properties of their respective owners.

Safety Information

Please read the following important information carefully before using this product.

- Do not take apart or attempt to service the camera yourself.
- Do not drop or knock the camera. Improper handling may damage the product.
- Turn off the camera before inserting or removing the battery and memory card.
- Use only the type of battery that comes with the camera. Using other types of batteries may damage the camera and void the warranty.
- Do not touch the camera lens.
- Please do not expose the camera to harsh environments such as moisture or extreme temperatures, which may shorten the life of your camera or damage the battery.
- Do not operate or store the camera in dusty, dirty or sandy environments.

- Do not expose the lens to direct sunlight for extended periods.
- Download all pictures and remove the batteries from the camera if you are going to store the camera for long periods of time.
- Do not use abrasive cleansers, alcohol-based or solvent-based cleaners to clean the camera. To clean, wipe the camera with a slightly damp, soft cloth.

About This Manual

This manual provides you with instructions on how to use your GE digital camera. Every effort has been made to ensure that the contents of this manual are accurate, however General Imaging Company reserves the right to make changes without notice.

Symbols used in this manual

Throughout this manual, the following symbols are used to help you locate information quickly and easily:



Indicates useful information to consider.



Indicates precautions to be taken while operating the camera.

CONTENTS

WARNING	i	Set Display Language	13
SAFETY PRECAUTIONS	ii	Set Date/Time.....	14
BEFORE YOU START	1	About the LCD Screen	15
Preface.....	1	Using the Modes.....	16
Copyright.....	1	Display Setting.....	16
Trademarks	1	LCD Screen Display	17
Safety Information	1	Still Picture Mode Display	17
About this Manual	2	Video Shooting Mode Display.....	19
Symbols used in this manual.....	2	Playback Mode Display.....	20
CONTENTS.....	3	Using the Mode Button	21
GETTING READY	7	Shooting in Auto Mode.....	22
Package Contents	7	Manual Mode.....	22
Camera Views.....	8	Panorama.....	23
Insert the Battery and SD/SDHC Card (card not included).....	10	Manual Scene Mode (SCN).....	24
Turning On and Off.....	12	ASCN	25
Setting Language and Date/Time.....	13	Landscape	25
		Sport	25

Beach.....	25	Night Portrait.....	26
Sunset.....	25	Sketch.....	26
Fireworks.....	25	Anti-shake.....	26
Night Landscape.....	25	Auto Scene Mode (ASCN).....	27
Snow.....	25	BASIC OPERATION	29
Children.....	25	Shooting in Auto Mode.....	29
ID.....	25	Using the Zoom Function.....	29
Glass.....	25	Basic Functions Menu.....	30
Photo Frame.....	25	Flash.....	30
Panning Shot.....	26	Self-Timer Setting.....	31
Text.....	26	Macro Mode.....	32
Portrait.....	26	SET Function Menu.....	32
Fish Eye.....	26	Exposure Compensation.....	32
Party.....	26	ISO.....	33
Indoor.....	26	Blink Detection.....	33
Leaf.....	26	PLAYBACK	34
Museum.....	26	Viewing Photos and Videos.....	34

Thumbnail View	35	Movie Mode Menu	45
Using Zoom on Playback (for still pictures only).....	36	Image Pixel	45
Using the Delete Button.....	37	Playback Menu.....	46
USING THE MENUS	38	Protect.....	46
Still Menu.....	38	Delete	47
Size	38	DPOF (Digital Print Order Format).....	48
Continuous Auto Focus (AF).....	39	Trim.....	49
Continuous Capture Setting	39	Red-Eye Reduction	49
Focus Setting	40	Rotate	50
Image Color Setting.....	40	Slideshow.....	50
White Balance Setting	41	Setup Menu	51
Setting Menu	42	Beep	51
Quality.....	42	Power Saver	52
AF-Assist Beam.....	43	Language.....	52
Digital Zoom.....	43	Zone	53
Date Imprint.....	44	Date/Time.....	53
Quick Review.....	44	File / Software	53

Format Memory.....	53	Print without Date.....	62
Copy to Card (Copy internal memory to memory card).....	54	Print Index.....	63
File Numbering.....	54	Print DPOF (Digital Print Order Format).....	64
Reset Settings.....	55	Exit.....	64
FW Version (Firmware version).....	55	APPENDICES	65
Transmission.....	56	Specifications.....	65
Connecting to a PC.....	56	Error Messages.....	69
Setting the USB Mode.....	56	Troubleshooting.....	71
Transferring Files to your PC.....	56		
Connecting to a PictBridge Compatible Printer.....	58		
Setting the USB Mode.....	58		
Connecting the Camera and Printer.....	59		
Video System.....	60		
Using the PictBridge Menu.....	61		
Print with Date.....	61		

GETTING READY

Package Contents

Your package should contain the camera model you purchased along with the following items. If anything is missing or appears to be damaged, please contact General Imaging.



Warranty Card

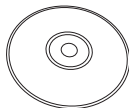

CD-ROM (Optional)



Wrist Strap

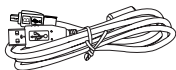

USB Cable

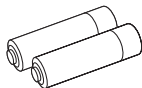

AA-size Alkaline Batteries

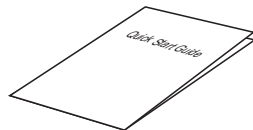

Quick Start Guide

Camera Views

Front View

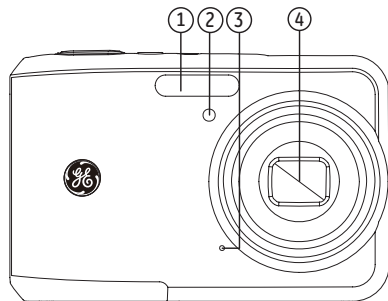

Back View

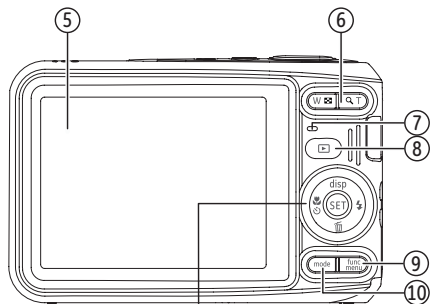

Right View

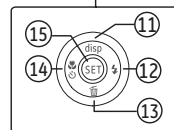
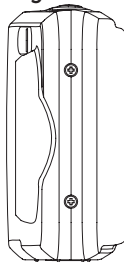

Top View

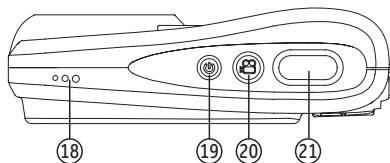

Bottom View

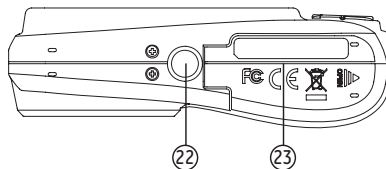

Left View

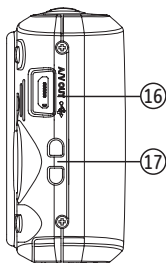

1	Flash	13	Delete/Down Button
2	AF Assist Beam/Timer indicator	14	Auto-Timer Shooting Button/Left Button
3	Mic	15	Function/SET Button
4	Lens	16	USB/AV Port
5	LCD Screen	17	Wrist Strap Mount
6	Zoom Button	18	Speaker
7	Power Indicator	19	Power Button
8	Playback Button	20	Movie button
9	Menu Button	21	Shutter Button
10	Mode Selection Button	22	Tripod Mount Point
11	Disp/Up Button	23	Memory Card/Battery Compartment
12	Flash Mode/Right Button		

Insert the Battery and SD/SDHC Card (card not included)

1. Open the battery compartment.

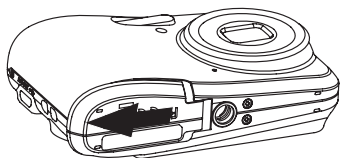

2. Insert the battery while observing the correct polarity.

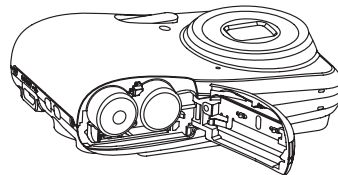
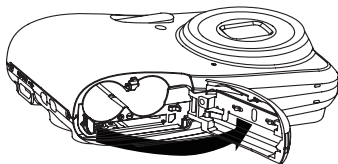
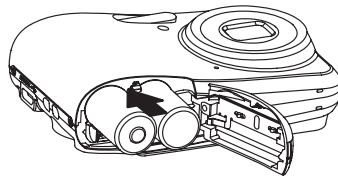

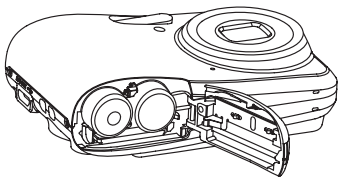
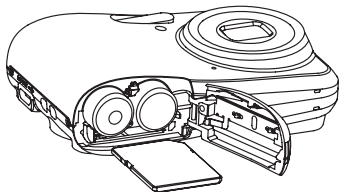

3. Insert an SD/SDHC card (not included) into the memory card slot as shown.

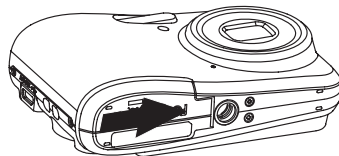
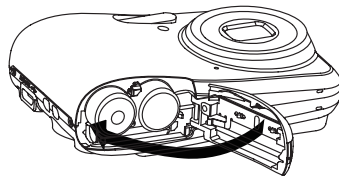

4. Close the battery compartment.



 Optional SD/SDHC cards are not included. The use of 64 MB to 32 GB memory cards from recognized manufacturers such as SanDisk, Panasonic and Toshiba are recommended for reliable data storage.

 To remove the SD/SDHC card, open the battery compartment and gently push the card to release it. Pull the card out carefully.

Turning On and Off

Press the Power button to turn the camera on. To turn the camera off, press the Power button again.

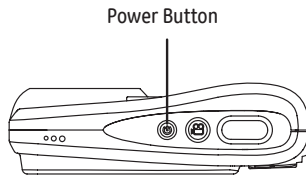

When the camera is turned on, it will default to the shooting mode last used. You can use the Mode button on the back to switch between modes.

Setting Language and Date/Time

 The Date/Time and Language setup page will automatically appear when the camera is turned on for the first time.

To set the display language and date/time, go to the following setup options in the General Setup Menu.

- Language
- Date/Time

To access the **General Setup Menu**, follow the steps below:

1. Press the **Power** button to turn the camera on.
2. Press the  button, press Up/Down button to switch between menus, select Set Menu, press SET button to enter Set Menu.

Set Display Language

1. In the General Setup Menu, press Up/Down button to select Language, press SET or Right button to enter setting mode.
2. Use the Up/Down/Left/Right buttons to select the desired language.
3. Press the SET button to confirm the setting.

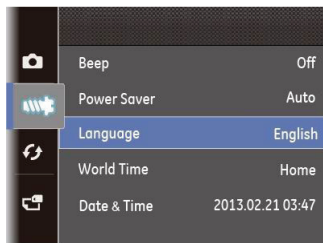

Set Date/Time

1. In the General Setup Menu, press Up/Down button to select Date/Time, press SET or Right button to enter setting mode.
2. Press Up/Down to select the date display mode, press right button to select the item to be set, press Up/Down button to select the required value.
3. Press the SET button to confirm the setting.

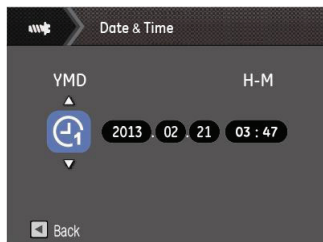

About the LCD Screen

When you turn the camera on, various icons are shown on the LCD screen to indicate the current camera settings and status. To learn more about the displayed icons, see “LCD Screen display” on page 17.

LCD Screen Notes:

Extremely high-precision technology has been used to manufacture the LCD screen so that most of the pixels are operational for use. However, there may be some minute points (black, white, red, blue or green) that consistently appear on the LCD screen. These points are normal in the manufacturing process and the recorded image is not affected in any way.



Avoid exposing the LCD screen to water; please remove any moisture on the LCD screen with a soft, dry cleaning cloth.



If the LCD monitor is damaged, take particular care with the liquid inside the monitor. If any of the following situations arise, take the recommended action immediately as indicated below:

- If liquid from the LCD comes in contact with your skin, wipe the area with a cloth and then wash thoroughly with soap and running water.
- If liquid from the LCD gets into the eyes inadvertently, rinse with water immediately and seek medical assistance.
- If liquid from the LCD is swallowed, rinse your mouth thoroughly with water. Drink large quantities of water and induce vomiting. Then seek medical assistance immediately.

Using the Modes

Display Setting

Press the **disp** button to toggle between these modes:
Default, Grid, and Clean.

Default mode: Display the camera parameters on screen



Grid: Camera parameters with Grid and Histogram

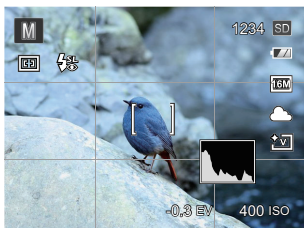

Clean: Does not display any additional icons

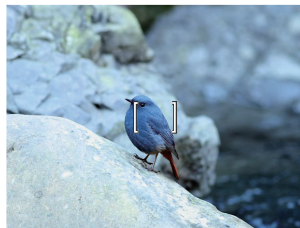

LCD Screen Display

Still Picture Mode Display

Mode:  **M** **SCN** 

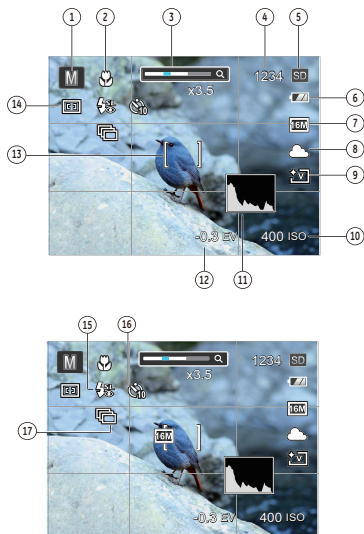

1 Shooting Mode Icons



Auto Mode



Manual Mode



Scene Mode



Panorama Mode

2 Macro Mode

3 Zoom

4 Remaining number of pictures

5 SD Memory card/built-in memory

6 Battery Status

7 Image Size

8 White Balance (Adjustable only in **M** Mode)

9 Picture Color (Adjustable only in **M** Mode)

10 ISO Value (Adjustable only in **M** Mode)

11 Histogram

12 Exposure Compensation (EV value) (Adjustable only in **M** Mode)

13 Focus Frame

14 AF Mode



Single-AF



Multi-AF

15 Flash Mode



Force Off



Flash Auto



Force Flash



Slow Sync.



Slow Sync. + Red-Eye



Red-Eye Reduction

16 Self-Timer



2sec



10sec



Smile

17 Continuous Shot



Off



On

Video Shooting Mode Display

Mode : 

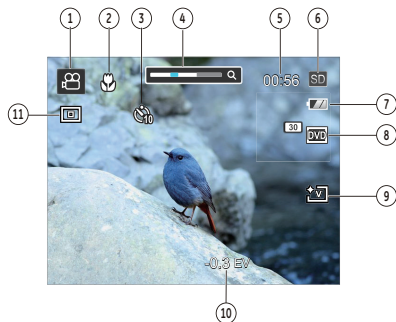

1 Video Mode Icon

2 Macro Mode

3 Self-Timer

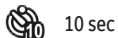

4 Zoom Value Scale (Displayed only when zoom is activated)

5 Remaining time for video recording

6 SD Memory Card/Built-in Memory

7 Battery Status

8 Video Quality

9 Picture Color

10 Exposure Compensation (EV value)

11 Metering



For optimal video shooting, it is recommended that a SD memory card be used. If you shoot video using only the internal memory, the results may have image jitter, noise and shortened recording times.

Playback Mode Display

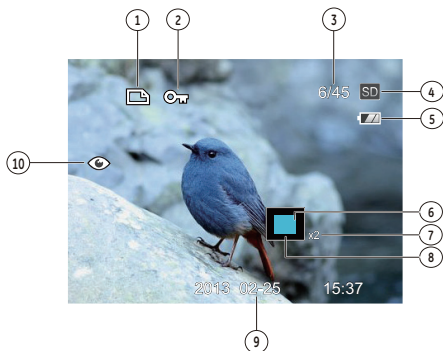

Mode : 



- 1 DPOF File
- 2 File Protection
- 3 Memory Space (this picture/total number of pictures)
- 4 SD Memory Card/Built-in Memory
- 5 Battery Status
- 6 Zoom Magnification Area
- 7 Image Zoom Ratios
- 8 Image Zone
- 9 Shooting Date
- 10 Red-Eye Reduction

Using the Mode Button

This GE camera provides a convenient Mode Button that allows you to switch easily between different modes. After pressing the mode button to enter the mode selection menu, press the Left/Right button to choose the selected mode. Press the SET button to confirm your selection. All the available modes are listed as follows:

Mode Name	Icon	Description
Auto Mode		The camera selects all the settings automatically
Manual Mode	M	Many of the camera settings can be configured manually in this mode
Scene Mode	SCN	Choose from 23 different scene types and effects for your photos
Panorama Mode		In this mode, up to 4 frames can be stitched together to create a single panoramic photo
Movie Mode		Switch to record videos

Shooting in Auto Mode

Auto Mode is the easiest mode to take photos. While operating in this mode, the camera automatically optimizes your photo settings for best results.

Follow these steps:

1. Press **mode** button to select Auto Mode ().
2. Compose your picture in the LCD screen and press the Shutter button halfway to focus on the subject.
3. The focus frame in the middle of the LCD will turn to green when the subject is properly in focus.
4. Press the **Shutter button** completely down to capture the image.

Manual Mode **M**

When selecting **M** (Manual Exposure) Mode, you can set EV/ISO.

1. Press **mode** button to select Manual Exposure Mode **M**, press **SET** to confirm.

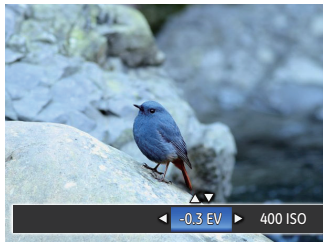

2. Press **SET** to confirm, Press the Up/Down button to select the parameter adjustment.
3. Press the **SET** button to confirm the settings and enter the shooting screen.

Panorama

Panorama Mode allows you to create a panoramic picture. The camera will automatically compose a panoramic picture using the individual shots that you take.

Follow these easy steps to create a panoramic picture:

1. Press mode button to select Panorama Mode ().
2. Use the Left/Right buttons to specify the direction of picture taking, and then in 2 seconds the panoramic sequence will commence automatically.
3. Compose the first view of the panoramic picture on the LCD screen and press the Shutter button to capture the image.
4. After the first shot is taken, the semi-transparent image of the first shot will appear at the edge of the screen. You can use this image to compose your picture before you press the Shutter button to capture and finish manual stitching.



5. If continuous pictures are less than 4 shots, press SET button, the camera will stitch the pictures automatically. Press playback button to enter playback mode to see the effect.
6. If you take 4 pictures, the camera will stitch the pictures automatically. Press playback button to enter playback mode to see the effect.



After selecting Panorama mode, Flash, Self-timer, Macro mode and Exposure Compensation cannot be adjusted.



Pictures cannot be deleted, nor the zoom adjusted until the series is finalized.



In Panorama mode, up to 4 photos can be captured when the image size is set at 2MP.







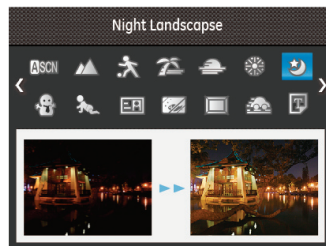





Manual Scene Mode (SCN)











In **Manual Scene Mode**, you can select from a total of 23 scene types to match your needs. Select the desired scene for the occasion and the camera will automatically adjust the optimal settings for you.

Press the SET button to enter Scene Mode. The LCD will display a menu like the example below:









Select a scene using the Up/Down/Left/Right button and press the SET button.

Mode name	Description
 Auto Scene	Identifies the scene automatically; Person, Backlighting, Landscape, Macro, Night Scene, Night Scene with subject, Auto.
 Landscape	For landscapes. Vivid reproduction of green and blue.
 Sport	For fast-moving subjects. Capture sharp action shots with minimal blur. This mode is not recommended for shooting indoors.
 Beach	For taking pictures in areas with strong sunlight.
 Sunset	For sunsets. Capture subjects in strong sunlight.
 Fireworks	For fireworks at night. Slower shutter speed adjusted for brilliant images. The use of a tripod is recommended.
 Night Landscape	For night scenes. The use of tripod is recommended.
 Snow	For snow scenes. Reproduce natural and clear white scenes.
 Children	Turn off flash automatically. Avoids disturbing subject, suitable for taking photos of children.
 ID	For shooting ID size photos. (It is recommended to print using 6-inch 4R (6X4) photographic paper).
 Glass	For objects behind transparent glass.
 Photo Frame	For adding interesting frame effects to the photo.

Mode name	Description
 Panning Shot	Produces background image blur that emphasizes the motion of the main subject.
 Text	For taking pictures of text, documents or white boards.
 Portrait	The best setting for portrait shooting, enables AE/AF for faces.
 Fish Eye	For interesting fish eye effect.
 Party	For taking pictures of large groups or in areas with uneven lighting.
 Indoor	For indoor settings. Reduce blur and improve color accuracy.
 Leaf	For plants. Capture brilliant shots of greenery and blossoms.
 Museum	For museum or flash-free areas. Retain color and reduce blur.
 Night Portrait	For portraits against night scenery.
 Sketch	For taking photos with pencil sketch effect.
 Anti-shake	Optical Image Stabilization to take clear pictures in the handheld state.

Auto Scene Mode (ASCN)

In the "ASCN" mode, different recording conditions are detected intelligently and the most suitable settings will be automatically selected.







Icon	Mode name	Icon	Mode name
	Landscape Mode		Night Landscape Mode
	Portrait Mode		Macro Mode
	Night Portrait		Auto Mode
	Backlit Portrait		

To use "ASCN":

1. Press mode button to select "SCN" mode, then select "ASCN" function. LCD screen will be shown as follows:



2. Hold the camera steadily and aim at the subject. The optimum scene mode will be selected automatically.
3. Press the Shutter button halfway down to focus.
4. Press the Shutter button all the way down to take the picture.

Mode name	Description
 Landscape Mode	For landscapes, ASCN will automatically adjust the exposure and reproduce vivid green and blue colors.
 Portrait Mode	The best mode for shooting portraits, enables AE/AF for faces.
 Night Portrait	When you take portraits at night, or in low light conditions, ASCN will automatically adjust the exposure for people and night scenes.
 Backlit Portrait	When the sun or any other light source is behind you, ASCN will automatically adjust the foreground exposure to produce the best pictures possible.
 Night Landscape Mode	For night scenes, ASCN will automatically increase the ISO value to compensate for low light.
 Macro Mode	To produce more detailed close-ups, ASCN will automatically engage the camera's Macro mode and automatically focus the lens.
 Auto Mode	The camera will automatically adjust the exposure and focus to ensure the best possible pictures.

BASIC OPERATION

Shooting in Auto Mode

Auto mode is the easiest mode to take photos. While operating in this mode, the camera automatically optimizes your photos for best results.

To start shooting, do the following:

1. Press the **Power button** to turn the camera on.
2. Press **mode** button to select Auto Mode ().
3. Compose your picture in the LCD screen and press the **Shutter button** halfway down to focus on the subject.
4. The focus frame in the middle of the LCD will turn to green when the subject is properly in focus.
5. Press the **Shutter button** down all the way to capture the image.

Using the Zoom Function

Your camera is equipped with two types of zoom functions: optical zoom and digital zoom. Press the Zoom button of the camera to zoom in or out on the subject while taking pictures.

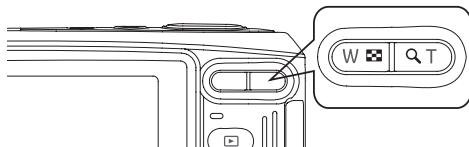

Zoom indicator (See "Digital Zoom" on page 43)

When reaching the critical point of optical / digital zoom, the camera will temporarily stop zooming; if you release and press the Zoom button again, it will automatically switch between optical and digital zoom.

Basic Function Menu



The Basic Function menu includes flash, self-timer, macro, and continuous capture.





Set the basic functions in the following steps:



Flash

1. Press Right/Flash button to enter function menus.



-  Force Off
Flash is turned off.
-  Flash Auto
Camera flash goes off automatically based on existing light conditions.

-  Force Flash
The flash will fire with each shot even if there is enough available light to take the photo without flash.
 -  Slow Sync.
This allows for night scenery photos that include people in the foreground. The use of a tripod is recommended when shooting with this setting.
 -  Slow Sync. + Red-Eye
Using this mode for slow synchro shots with red-eye reduction.
 -  Red-Eye Reduction
The camera emits a brief flash before the picture is taken to reduce red-eye effects.
2. Press Left/Right button to select the option setting, press SET button to confirm the setting and exit the interface.

-  When  appears, it represents the flashlight is charging.



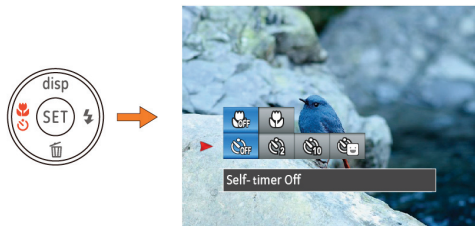

Self-Timer Setting

Use this function to take pictures at pre-set intervals. The camera shutter speed can be set for 2 seconds, 10 seconds or by smile detection.

1. Press  button to enter function menu.



2. Press Up/Down button to enter self-timer function menu.
3. Press Left/Right button to select self-timer function menu.

-  Self-timer Off
Disables the self-timer.
 -  Self-timer 2sec
A single picture is shot 2 seconds after the Shutter button is pressed.
 -  Self-timer 10sec
A single picture is shot 10 seconds after the Shutter button is pressed.
 -  Self-timer Smile
Once the Shutter button is pressed a photo is taken as soon as a smile is detected on the LCD screen.
4. Press the SET button to confirm the settings and exit the menu.



Macro Mode

The Macro setting is ideal for shooting small objects or close-up photos. This mode allows you to focus on subjects very close to the camera.

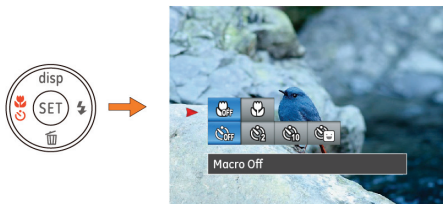
1. Press  button to enter macro function menu.



2. Press the Left/Right button to select the following two modes:

-  Macro Off
Select this option to disable Macro.
-  Macro On
Select this to focus on subjects 5cm from the lens.

3. Press the SET button to confirm the settings and exit the menu.

SET Function Menu

The SET function menu of the camera includes EV, ISO. The appropriate function setting can give you better photographs and videos.

Exposure Compensation

The exposure compensation feature allows you to adjust the light exposure value to control the brightness of the image.

1. Press SET button to enter SET function menu.

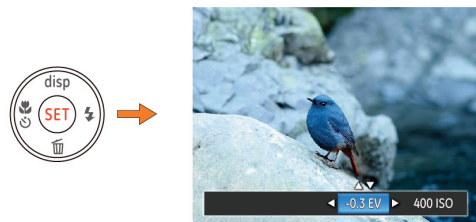

2. Press Left/Right to select the required function menu, press SET button to confirm the setting and exit the menu.
3. The adjustable range of exposure value is from EV -2.0 to EV+2.0.

ISO

The ISO function allows you to set the sensitivity of the camera's sensor to light. To improve the performance in darker environments, a higher ISO value is required. On the other hand, a lower ISO value is needed when in bright conditions. (The ISO setting is only available when the camera is in the **M** Manual mode).

Pictures taken with higher ISO will generally have more noise than those taken with lower ISO.

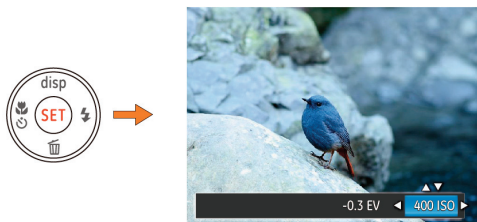

The options of ISO include automati, 80, 100, 200, 400, 800, and 1600.

Blink Detection

Blink Detection is enabled by default unless disabled by the user. When shooting, if a subject is detected with closed eyes, the Blink Detection icon (☺) will appear on the screen to indicate possible blink.

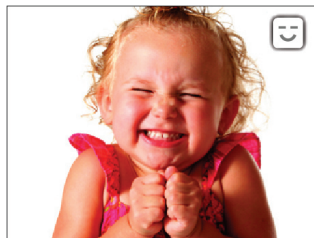

Viewing Photos and Videos

To view the captured photos and video clips on the LCD screen:

1. Press the  button to enter the **Playback** mode. The last recorded photo or video clip will appear.
2. Use the **Left/Right** navigation buttons to scroll through the photos or video clips stored in the internal memory or memory card.
3. To play a selected video clip, press the SET button to enter the movie playback mode.

During video playback, the operating instructions will appear on the screen. Press the Left/Right button, and press the SET button for confirmation.

The operating instruction icons are as follows.

- | | | | |
|---|-----------------|---|-----------------|
| 1 | Increase Volume | 4 | Decrease Volume |
| 2 | Pause | 5 | Rewind |
| 3 | Fast Forward | | |

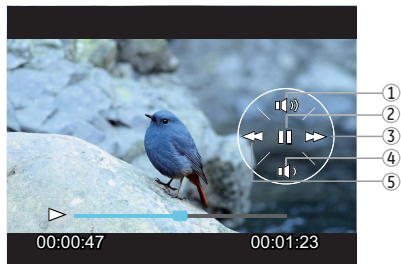

When playing a movie, press the Up/Down button to increase or decrease the volume. To mute the audio, press and hold the Down button until the  appears.

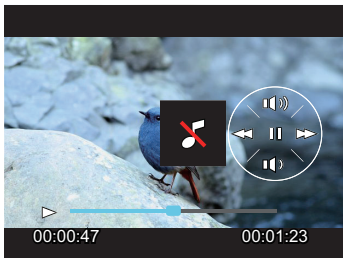

Thumbnail View

When in playback mode, press **W** on the zoom button to display thumbnail images of photos and videos on the screen.



1. Slide the zoom lever to switch between 3x3 and 4x4 thumbnails.
2. When displaying 3x3 and 4x4 thumbnails, press the Up/Down/Left/Right button to select a picture or video clip to view.





If the ► indicator appears on the LCD, then a movie file is currently being displayed.



Press the SET button to restore a preview icon to its original image size.

Using Zoom Playback (for still pictures only)

The zoom buttons can also be used during playback. This allows you to magnify photos between 2x to 8x.

1. Press the (◻) button to switch to playback mode.
2. Use the Left/Right navigation buttons to select a photo to magnify.
3. Press the T on the zoom button to zoom in.
4. Use the Zoom button to zoom in and out. The zoom magnification area frame and the frame of the whole photo will display on the screen.

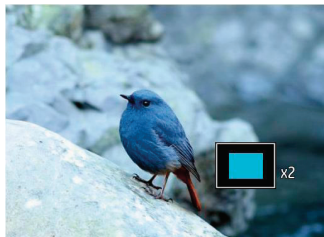

5. Use the navigation buttons to pan across the image.
6. Press the SET button to return the image to its original scale.



Movie images cannot be magnified.

Using the Delete Button

In Playback Mode, you can press the Down/Delete button to delete pictures or videos.

To delete pictures or videos:

1. Press the  button to enter the Playback Mode.
2. Select a picture or video clip you want to delete with the Left/Right button.
3. Press the Down/Delete button and the delete screen will appear.
4. Select Delete One or the Back option with the Up/Down button and press the SET button for confirmation.



Erased photos/video clips cannot be recovered.



Please refer to page 47 for instructions on the Delete Menu options.

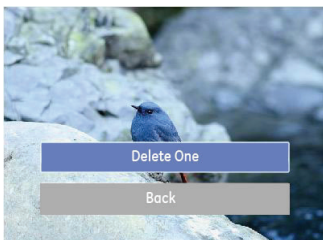

USING THE MENUS

Still Menu

Mode:  **M**

In any of the above Photo Modes, press the  button to go to the Photo Setup Menu.

To adjust each setting:

In the shooting menu, press Up/Down button to switch between shooting menu and camera setting menu. Select the screen which has function options and press Left/Right button to select function.

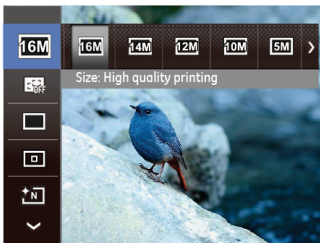



 After selecting a function, you can press the Up button to return to the Still Picture menu for other Photo Setup or Camera Setup pages. Or you can press the Down button several times to move to the next setup menu page.

 Refer to the following pages for more details about each setting.

Size

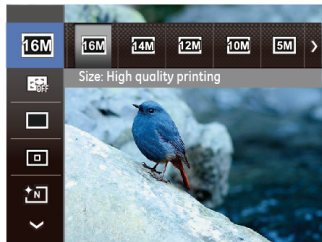
The size setting refers to the image resolution in pixels. A higher image resolution allows you to print that image in larger sizes without degrading the image quality.



 The bigger the number of recorded pixels is, the better the image quality becomes. As the number of recorded pixels becomes smaller, you will be able to record more images on a memory card.

Continuous AF

When Continuous AF is turned on, the camera will continually adjust focus automatically in response to any camera or subject movement.

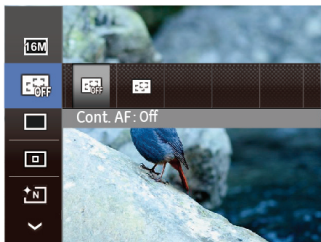

There are two options:



- Off
- On

Continuous Capture Setting

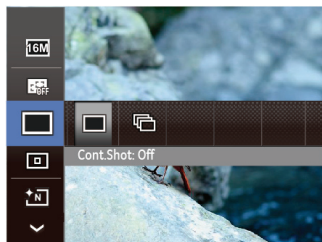
Use this setting to perform continuous shooting. After entering this mode, you can shoot multiple images by continuously holding the shutter button down.



There are two options:

-  Cont. Shot: Off
Turn off the Continuous Shot function.
-  Cont. Shot: On
Shoot at the rate of 2.3 pictures per second.
The resolution is lowered to 3 megapixels.

Focus Setting

This setting allows you to select different modes for optimum focus.

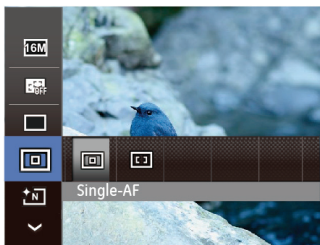

There are 2 options:

-  Single-AF
-  Multi-AF

Image Color Setting

Image color setting allows you to select different color effects.

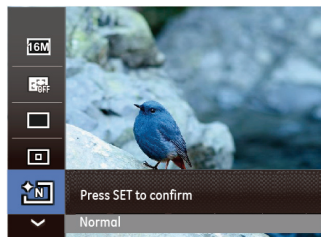







Image color setting effect has the following 4 options:







-  Normal
-  Vivid
-  Retro
-  Black and White

 Adjustable only in **M** Manual Mode.

White Balance Setting

The White Balance Setting allows you to adjust the color temperature for different lighting sources to ensure accurate color reproduction.



1. Press Left/Right button to select the following 7 modes:
 -  AWB
 -  Daylight
 -  Cloudy
 -  Fluorescent
 -  Fluorescent CWF
 -  Incandescent
 -  Manual WB (Press the Shutter button to detect WB)
2. Press the SET button to confirm the settings and exit the menu.

 Adjustable only in **M** Manual Mode.

Setting Menu

Mode :  M

Press  button to enter shooting menu.

1. Press Up/Down button to switch among shooting menus and select setting menu.

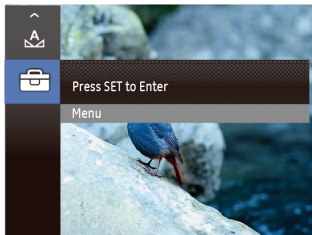

2. Press SET or Right button to set menu.

Quality

The camera's quality setting adjusts the compression ratio of the images. Higher quality settings produce better quality photos, but will take up more memory space.

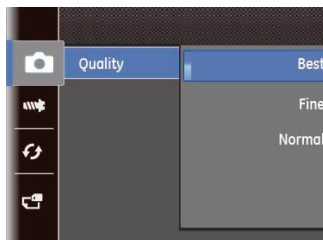

There are three options for picture quality:

- Best
- Fine
- Normal

AF-Assist Beam

This option can turn on or turn off the AF assist lamp. The AF assist beam is useful for focusing in the dark or in low lighting conditions.

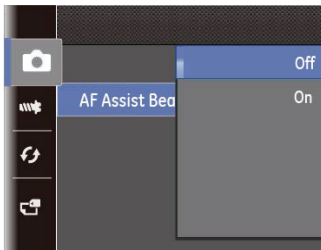

Digital Zoom

Use this setting to enable or disable the Digital Zoom function. When Digital Zoom is turned off, only the optical zoom is functional.



Date Imprint

Include a Date/Time stamp in the photo image.

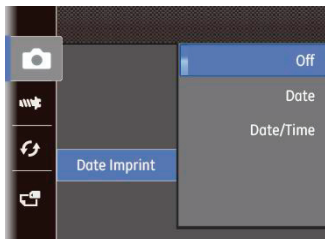

- Off
- Date
- Date / Time

Quick Review

This setting refers to the brief photo review immediately after taking a picture. The picture stays on the LCD screen for an adjustable period of time.

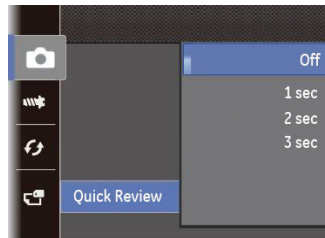

Four options are available:

- Off
- 1 sec
- 2 sec
- 3 sec

Movie Mode Menu

Mode : 

Press mode dial to select  mode.

1. Press  button to enter  menu.

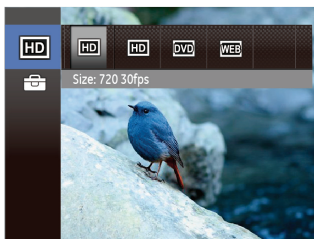

2. Press Up/Down button to select the menu options to be set.
3. Press Left/Right button to select functions.

Image Pixel

The quality of photos can be changed by selecting image resolution ratio.

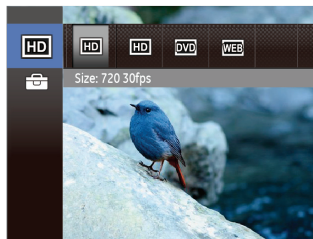

The speed requirements for reading and writing high resolution pixel images to a SD card are as follows:

No.	Image Pixel	Frame	Requirement	Recommendation
1	1280x720	30	Class 2	Class 4



Recording time limit above (1280 x 720p) 29 fps format is under 29 minutes.

Playback Menu

Mode : 

In Playback mode, press the  button to enter the Playback menu.

1. Press Up / Down button to switch between playback menus.
2. Press SET or Right button to playback setting menu.

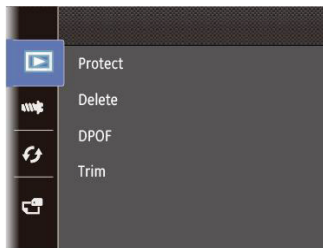

Please refer to the following sections for detailed instructions on the various menu options.

Protect

To prevent any pictures or videos from being accidentally erased, use this setting to lock one or all of the files.



To protect/unprotect a picture or video:

1. Use Up/Down arrow button to select Protection, press the SET or Right button to enter the submenu.

2. Press Up/Down button to select between protection options:

- Single, to protect a single selected photo or video
- All, to protect all photos and videos stored in built-in memory and/or SD card

Press SET button to confirm and enter photo/video protection interface.

3. Select Protect to lock displayed photos or videos, or select Unprotect to unlock, then press SET and select "Back" to return to the playback menu.

Delete

There are two ways to delete files.

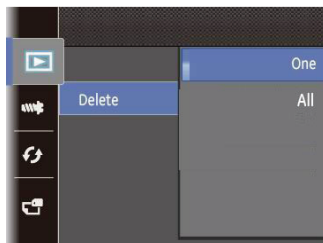

• Delete One:

1. In the Delete setting, select **Delete One** and then press the SET or **Right** button.
2. Press the Left/Right button to locate the photo or video to be deleted. Press the Up/Down button to select item (Delete One: to delete the file or, Back: to return to previous menu) and then press SET to confirm.

- **Delete All:**

1. In the Delete option, select All and then press the SET button.
2. Use Up/Down button and select Delete All to delete all files, or select Exit to return to the menu.



The “🔒” indicator means a file is protected. File protection must be removed first before a file can be deleted.



Deleting files will cause DPOF settings to be reset.

DPOF (Digital Print Order Format)

DPOF allows you to record a selection of pictures that you would like to print, and will save your selection in the memory card, so that you can simply use your memory card at a photo kiosk or in-store without having to review and select photos you would like to print.



Trim

The Trim setting allows you to trim an area of a selected photo and save it as a new photo.

To trim a picture:

1. Select cutting function.
2. Select "Yes" to confirm cutting, use the zoom lever and direction buttons to select the part to be cut, and to select the desired photo.

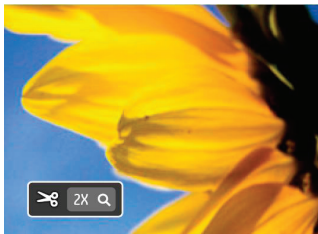



3. Press SET button and 'Save Change?' will appear. Select "✓" to confirm changes and save it as a new image, or select "✗" to cancel changes and return to the previous menu.



The image cannot be cropped again when it is cropped to 640 x 480.

Red-Eye Reduction

Use this setting to remove red eye in your photos.

1. In the playback mode, press Left/Right button to select the photo which needs red-eye reduction.
2. In the  menu, select  to set, press SET to enter setting screen.
3. Press Left/Right button to select corresponding menu, or cancel and return playback menu.

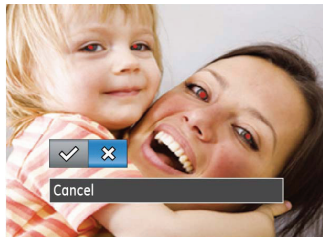

 : Red-Eye Reduction

 : Cancel



4. Press the SET button to confirm the setting.



For best results, the face of the subject should be relatively large on the LCD screen, the subject should be facing the camera, and the eyes should be as large as possible.

Rotate

You can use this setting to change the orientation of the picture.

1. In the playback mode, press Left/Right button to select the photo which needs rotation.
2. In the  menu, select  to set, press SET to enter setting screen.
3. Press Left/Right button to select rotation direction, or cancel and return play menu.

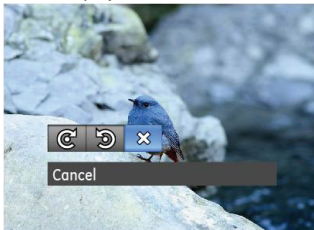

 : Turn Right

 : Turn Left

 : Cancel

4. Press the SET button to confirm the setting.



Videos and panoramic pictures cannot be rotated.



The rotated picture file will replace the original one.

Slideshow

This setting allows you to view all the stored pictures as a slideshow.

1. Press  button to enter playback screen.
2. Press SET button to enter slide option.
3. Press Left/Right button to select slide playing, or cancel and return to play menu.

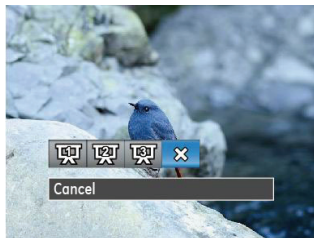



- Effect 1: interval 1sec, Melodious music
- Effect 2: interval 1sec, Enthusiastic music
- Effect 3: interval 1sec, Peaceful music

4. Press the SET button to confirm the setting.

Setup Menu

Mode :  M   

You can enter the Setup menu from any mode, just press  button, press Up/Down button to switch, select  setting menu, press SET button to enter, then press Up/Down button to select  basic setting menu.

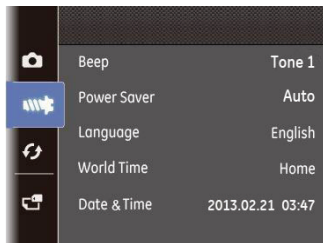

To adjust the settings:

1. Select the setting menu for the options you want to choose, and press SET or Right button to enter the appropriate menu.

2. Switch between different functions with the Up/Down button.
3. Press the SET or Right button to enter the submenu.



After selecting a function option, you can press the Up button to return to the menu for other Camera Setup pages. Or you can press the Down button to switch to the next menu page.

Refer to the following pages for more details about each setting.

Beep

You can change the tones used for button presses, time lapse and sound effects during power on/off.

To change these settings:

1. Select the **Beep** setting from the **Setup** menu as described previously.

2. Press Up/Down button to select volume control:

- Tone 1: Low
- Tone 2: Medium
- Tone 3: High

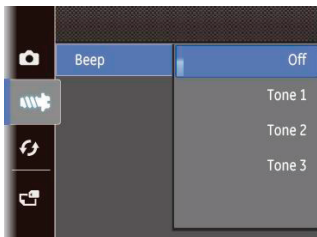

3. Press Right button to enter, and press Up/Down button to select sound type, then press SET button to confirm setting.



After selecting a sound type, the following functions can be adjusted together: alarm setting, shutter, button tone, and time lapse.

Power Saver

This setting allows you to save power and get the maximum possible running time for your batteries. Follow the steps below to turn off the LCD screen and camera automatically after a period of inactivity.

1. Select the **Power Save** setting from the **Setup** menu as described previously.
2. Press the Up/Down button to select the power items for the screen and camera and press the Right button.

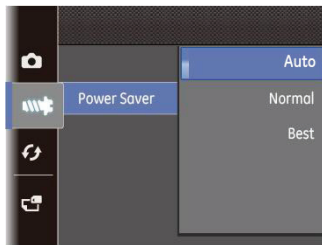



3. Press the Up/Down button to adjust the selected item.
4. Press the SET button to confirm.

Language

See "Setting the Language" section on page 13.

Zone

The Zone setting is a useful function on your overseas trips. This feature enables you to display the local time on the LCD screen while you are overseas.

1. Select the **Zone** setting from the **Setup** menu as described previously. The world time screen will appear.
2. Use the **Up/Down** navigation buttons to switch between the hometown () and travel destination () fields.
3. Use the **Left/Right** navigation buttons to select a city close to the desired time zone. Then press the SET button to confirm.

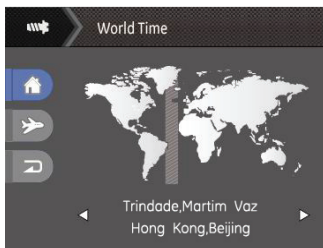

Date/Time

See "Setting the Date and Time" section on page 14.

File / Software

Format Memory

Please note: formatting enables you to delete all contents in the memory card and built-in memory, including protected photo and movie files.

To use this setting:

1. Select **Format Memory** in the File and Software menu.
2. Use the **Up/Down** navigation button to select **Yes** or **No**. Then press the SET button to confirm the setting.

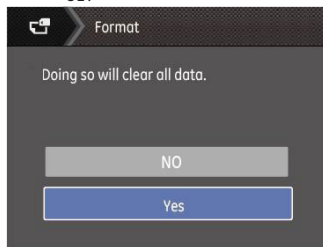

3. Select **Yes**, the camera will format the selected media.



Note that when you perform the Format Memory function, it only formats the active memory. If an SD memory card is inserted, the SD memory card is active and will be formatted. If there is no SD memory card, the internal memory is active and the internal memory will be formatted. Formatting the SD memory card will not automatically format the internal memory.

Copy to Card (Copy internal memory to SD memory card)

Use this setting to copy the files stored in the camera's internal memory to an SD memory card.

1. Select **Copy to Card** in the **File/Software** menu, then press **Right**.
2. Use the **Up/Down** navigation buttons to select **Yes** or **No**. Then press the **SET** button to confirm the setting.

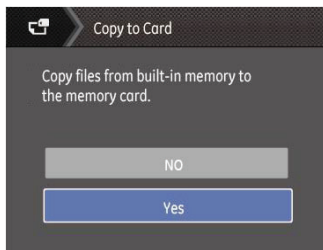

If there is no card available in the camera, this function will not be displayed.

File Numbering

After you take a picture or video clip, the camera will save it in sequential order. You can use this to reset the file numbering to 1. (When the files in the memory card exceed 9999, and the photos in the last file exceed 999, a warning will indicate that the memory card is full).

1. Select **File Numbering** in the **File/Software** menu, then press **Right**.
2. Select the option with the **Up/Down** button and press the **SET** button for confirmation.

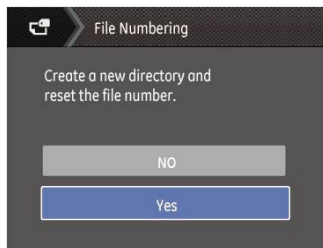

Reset Settings

Use this setting to restore the camera to its original factory default settings.

1. Select **Reset Settings** in the **File/Software** menu, then press **Right**.
2. Use the **Up/Down** navigation buttons to select **Yes** or **No**. Then press the **SET** button to confirm the setting.

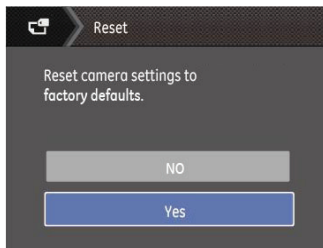

FW Version (Firmware Version)

Use this setting to view the current camera firmware version.

Select **FW Version** in the **File/Software** menu, then press **Right**.

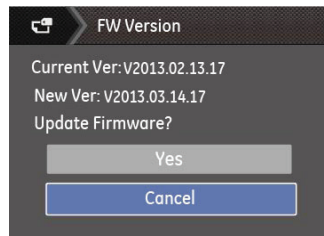

To update to the latest firmware version, you can go to the following website:
www.ge.com/digitalcameras and look under **Support**.

Transmission

Connecting to a PC

You can use a USB cable to connect the camera and copy (transmit) photos to a computer, printer or other device.

Setting the USB mode

The camera's USB port can be set to connect with either a PC or a Printer, the following steps will allow you to ensure that the camera is correctly configured to connect with a PC.

1. Go to the Transmission menu, then select USB connection with the Up/Down button, and press the Right button.
2. Use the Up/Down navigation buttons to select PC.
3. Press the SET button to confirm the setting.



Transferring files to your PC

Your computer will automatically detect the camera as a removable drive. Double-click the **My Computer** icon on the desktop to locate the removable drive and to copy folders and files in the drive to a directory on your PC as you would copy any typical folder or file.

Follow the steps below to connect the camera to a PC.

1. Make sure both the camera and PC are turned on.
2. Connect one end of the supplied USB cable to the USB/AV OUT port on your camera.
3. Connect the other end of the cable to an available USB port on your PC.

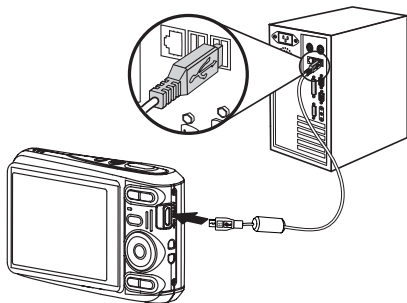

4. Disconnect the camera once transfer is completed.

If the USB option is set to [PC]:

Turn the camera off and disconnect the USB cable.

Windows operating system (Windows 2000, Windows XP, Windows Vista, Windows 7).

Click the [Safely remove the hardware] icon and remove the USB connector according to the appeared menu.



Macintosh

Drag the untitled icon to the Trash. ("Untitled")

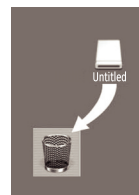

Connecting to a PictBridge Compatible Printer



PictBridge allows printing images from a memory card in a digital camera directly to a printer, regardless of brand. To find out if a printer is PictBridge compatible, simply look for the PictBridge logo on the packaging or

check the printer manual. With the PictBridge function on your camera, you can print the captured photos directly with a PictBridge compatible printer using the supplied USB cable, without the need for a PC.

Setting the USB Mode

Since the camera's USB port can be set to connect with either a PC or a Printer, the following steps will allow you to ensure that the camera is correctly configured to connect with a Printer.

1. Enter the camera setup menu to select USB Mode with Up/Down, then press the SET or Right button to enter.
2. Use the Up/Down button to select **Printer**.

3. Press the SET button to confirm the setting.



After the camera is reset, it will switch to PC mode automatically from USB mode.

Connecting the Camera and Printer.

1. Make sure both the camera and printer are turned on.
2. Connect one end of the supplied USB cable to the USB port on your camera.
3. Connect the other end of the cable to the USB port on the printer.

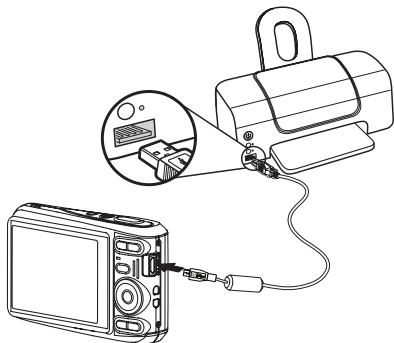

If the camera is not connected to a PictBridge compatible printer, the following error message will appear on the LCD screen.



-  The above error message would also appear if the USB mode were set incorrectly, in which case you should disconnect the USB cable, check the USB mode settings, ensure that the Printer is turned on, and then try connecting the USB cable again.

Video System

Use this feature to switch the video system from either NTSC or PAL.

1. Select **Video System** in the Transmission menu, then press Right.
2. Use the **Up/Down** navigation buttons to select **NTSC** or **PAL**. Then press the SET button to confirm.



The video output signal can be switched to NTSC or PAL to accommodate different regional TV standards. The appropriate setting will vary between regions.

NTSC: USA, Canada, Taiwan, Japan, etc.

PAL: Europe, Asia (excluding Taiwan), Oceania, etc.

Note: The TV output will not display properly if an incorrect video system is selected.

Using the PictBridge Menu

After setting the USB mode to Printer, the **PictBridge** menu will appear:

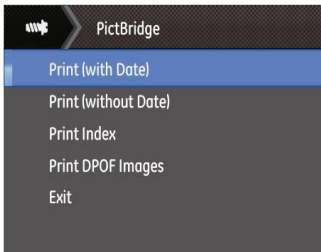

Press the Up/Down button to select a menu item, then Press the SET or Right button to enter this item.

Refer to the following sections for more detailed information on each setting.

Print with Date

If you have set the date and time of your camera, the date and time will be recorded and saved with each photo you take.

1. Select **Print with date** from the **PictBridge** menu. The following screen will appear:

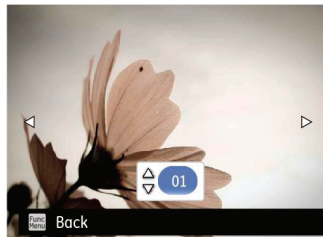

2. Use the **Left/Right** navigation buttons to scroll through the photos.

- Use the **Up/Down** navigation buttons to select the number of prints for the current displayed photo.
- Press the **SET** button and the following screen will appear:

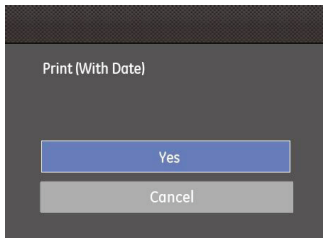

- Select "Yes", then press **SET** button: confirm print.
Select "Cancel", then press **SET** button: cancel print.

Print without Date

Use this setting to print the photos without dates on them.

- Select **Print without date** from the **PictBridge** menu.
The following screen will appear:

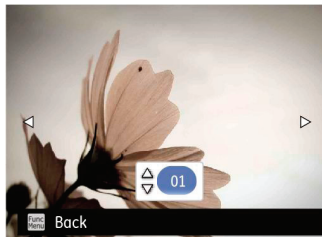

- Use the **Left/Right** navigation buttons to scroll through the images.
- Use the **Up/Down** navigation buttons to select the number of prints for the current displayed image.
- Press the **SET** button and the following screen will appear:

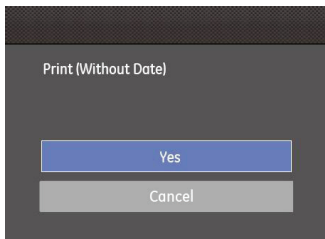

5. Select "Yes", then press SET button: confirm print.
Select "Cancel", then press SET button: cancel print.

Print Index

You can use this setting to print all indexes to show all photos currently in your camera.

1. Select **Print index** from the **PictBridge** menu. The following screen will appear:

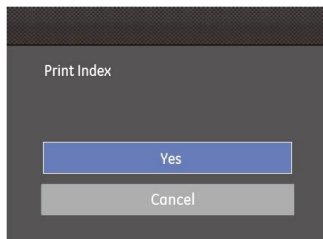

2. Select "Yes", then press SET button: confirm print.
Select "Cancel", then press SET button: cancel print.

Print DPOF (Digital Print Order Format)

To use DPOF printing, you must select the photos for printing using the DPOF settings before hand. See the "DPOF" section on page 48.

1. Select **Print DPOF** from the **PictBridge** menu. The following screen will appear:

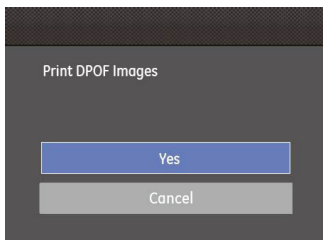

2. Select "Yes", then press SET button: confirm print.
Select "Cancel", then press SET button: cancel print.

Exit

To exit the **PictBridge** menu, select **Exit**. The "Remove USB cable" message will be displayed.

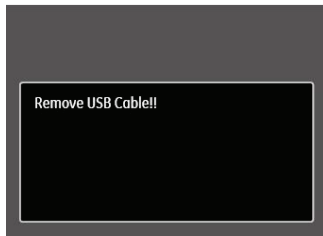

Disconnect the USB cable from the camera and printer.

Specifications



Design and specifications are subject to change without notice.

Active Image Sensor Pixels		16.15 Megapixels
Total Image Sensor Pixels		16.44 Megapixels [1/2.3"CCD]
Lens	Focal Length	4.9mm (Wide) – 19.6mm (Tele)
	[35mm film equivalent]	[27mm (Wide) – 108mm (Tele)]
	F number	F3.0 (Wide) – F6.6 (Tele)
	Lens Construction	7 groups 7 elements
	Optical Zoom	4x
	Focusing Range	Normal: (Wide) 23.6in. ~ ∞ / 60cm ~ ∞ (Tele) 39.3in. ~ ∞ / 100cm ~ ∞ Macro: 1.9in. ~ ∞ / 5cm ~ ∞ (Wide Only)
Anti-Handshake		Digital Image Stabilization
Digital Zoom		6x Digital Zoom (Combined Zoom: 24x)

Number of Recording Pixels	Still Image	(4:3) 16MP: 4608×3456, 10MP: 3648×2736, 5MP: 2592×1944, 3MP: 2048×1536, 0.3MP: 640×480	(3:2) 12MP: 4608×3072,	(16:9) 10MP:4608×2592 2MP: 1920×1080
	Movie	720p30, 720p15, VGA, QVGA		
Image Compression		Best, Fine, Normal		
DCF, DPOF (Ver1.1) Support		Yes		
File Format	Still Image	Exif 2.3 (JPEG)		
	Movie	Movie Format: MOV (Motion JPEG), Audio: G7.11 [Monaural]		
Shooting Modes		Auto, M, Movie, SCN [Auto Scene, Landscape, Sport, Beach, Sunset, Fireworks, Night Landscape, Snow, Children, ID, Glass, Photo Frame, Panning Shot, Text, Portrait, Fish Eye, Party, Indoor, Leaf, Museum, Night Portrait, Sketch, Anti-shake], Panorama		
Detection Features		Face, Smile, Blink		
Red-Eye Reduction		Yes		
Panorama Capture		0°~ 180° (Horizontal)		

LCD Display	2.7inch (230k Pixels)
ISO Sensitivity	Auto, ISO 80/100/200/400/800/1600
AF Method	Single AF, Multi-AF (TTL 9-point), Face-Detection
Exposure Metering Method	Artificial Intelligence AE (AiAE), Face AE
Exposure Control Method	Program AE (AE-Lock Available)
Exposure Compensation	±2EV in 1/3 Step Increments
Shutter Speed	1/2000 ~ 4 Seconds
Continuous Shooting	Yes
Playback Modes	Single Photo, Index (9/16 Thumbnails), Slide Show,
	Zoom (Approx. x2 ~ x8)
White Balance Control	AWB, Daylight, Cloudy, Fluorescent, Fluorescent CWF, Incandescent, Manual WB

Flash	Flash Method	Internal
	Flash Modes	Auto, Red-Eye Reduction, Forced Flash, No Flash, Slow Synchro, Red-Eye Reduction + Slow Synchro
	Shooting Range	(Wide) Approx. 11.8in. ~ 204.7in. / 0.3m ~ 5.2m (ISO800) (Tele) Approx. 19.6in. ~ 94.4in. / 0.5m ~ 2.4m (ISO800)
Recording Media		Internal Memory: Approx. 8MB
		SD/SDHC Card (Up to 32GB Support) [Nonsupport MMC Card]
Other Features		PictBridge, ExifPrint Support, Multi-Language Support (25 Languages)
Jacks		AV-OUT/USB 2.0 (Micro 5 pin USB)
Power		2 x AA Alkaline Battery, AA NiMH Battery [Not Included]
Shooting Capability (Battery Performance)		AA Alkaline Batteries: Approx. 120 shots (based on CIPA standards)
		AA NiMH Battery : Approx. 360 shots (CIPA Standards)
Operation Environment		Temperature: 32 ~ 104°F / 0 ~ 40°C, Humidity: 0 ~ 90%
Dimensions (W×H×D)		Approx. 3.6×2.4×1.0in. / 93.0×60.2×26.6mm (Based on CIPA Standards)
Weight		Approx. 4.1oz. / 116g (Body Only)

Error Messages

Messages	Explanation
Card error	<ul style="list-style-type: none">• The memory card is not formatted.
Card full	<ul style="list-style-type: none">• The memory card is full and cannot store any new images.
Exceeded maximum folder number.	<ul style="list-style-type: none">• This indicates that the SD card exceeded the maximum number of folders (999). This could cause a long read time during the camera's power up. Copy the data to your PC, format the memory card using the camera.
Picture error	<ul style="list-style-type: none">• The picture was not captured correctly.• The picture is corrupted.
No picture	<ul style="list-style-type: none">• There are no images in the memory card or in the internal memory.
Lens error	<ul style="list-style-type: none">• The lens is probably stuck and the camera will power off automatically.
System error	<ul style="list-style-type: none">• Unexpected error encountered.
Write protect	<ul style="list-style-type: none">• The write protection switch in the memory card is set to the "LOCK" position.
Improper alignment	<ul style="list-style-type: none">• When pictures were taken in Panorama mode, the direction of movement was incorrect.• While shooting in panorama mode, the movement is too slow and the shooting is not finished in 30s.

Messages	Explanation
Card is not formatted, format?	<ul style="list-style-type: none"> • Confirm whether the memory card should be formatted.
This image cannot be deleted	<ul style="list-style-type: none"> • The picture or video you are trying to delete is protected.
Warning!! Camera recording, please wait.	<ul style="list-style-type: none"> • No other actions allowed to perform during video/audio recording.
Warning!! Battery exhausted.	<ul style="list-style-type: none"> • The battery is out of charge.
This file cannot be played back	<ul style="list-style-type: none"> • The picture format cannot be recognized by the camera.
No connection	<ul style="list-style-type: none"> • The camera is not connected to the printer correctly.
Print error	<ul style="list-style-type: none"> • There is a problem with camera or printer.
Cannot print	<ul style="list-style-type: none"> • Check that the printer is out of paper or out of ink. • Check if the printer has a paper jam.

Troubleshooting

Problem	Possible causes	Solution
Camera does not turn on.	<ul style="list-style-type: none">• The battery has run out.• The battery is not inserted correctly.	<ul style="list-style-type: none">• Replace with a fully charged battery.
Camera turns off suddenly during operation.	<ul style="list-style-type: none">• The battery has run out.	<ul style="list-style-type: none">• Replace with a fully charged battery.
The picture is blurred.	<ul style="list-style-type: none">• The lens is dirty.•  appears when taking pictures.	<ul style="list-style-type: none">• Use a soft cloth to clean the lens on your camera.• Use the Image Stabilization mode.
Images and video files cannot be saved.	<ul style="list-style-type: none">• The memory card is full.	<ul style="list-style-type: none">• Replace the memory card with a new one.• Delete unwanted images.• Unlock the memory card.
No picture is taken when pressing the Shutter button.	<ul style="list-style-type: none">• The memory card is full.• No available space to store the files.• The mode dial is in Playback mode.	<ul style="list-style-type: none">• Replace the memory card with a new one or format the current memory card.• Delete unwanted images.• The memory card is locked.

Problem	Possible causes	Solution
Images cannot print from the connected printer.	<ul style="list-style-type: none"> • The camera is not connected to the printer correctly. • The printer is not PictBridge compatible. • The printer is out of paper or out of ink. • The paper is jammed. 	<ul style="list-style-type: none"> • Check the connection between the camera and printer. • Use a PictBridge compatible printer. • Load some paper in the printer. • Replace the ink cartridge in the printer. • Remove the jammed paper.
Writing to memory card is slow	<ul style="list-style-type: none"> • A Class 4 memory card or below may inhibit recording of slow the process down. 	<ul style="list-style-type: none"> • Please select HCSD or shoot after formatting this card.
Cannot write to the memory card	<ul style="list-style-type: none"> • Memory card is in write-protection state. • When shooting or recording, write-protection interruption in the memory card (like slower writing times) may not allow you to continue to shoot or record. . 	<ul style="list-style-type: none"> • Please replace a memory card. • Please shoot again.

<http://www.ge.com/digitalcameras>



imagination at work

Printed in China

© 2013 General Imaging Company

Follow us on



GE-C1640W-EN-0